

CHAPTER 17

Cellular Telephone and Satellite Networks

We discussed wireless LANs in Chapter 15. Wireless technology is also used in cellular telephony and satellite networks. We discuss the former in this chapter as well as examples of channelization access methods (see Chapter 13). We also briefly discuss satellite networks, a technology that eventually will be linked to cellular telephony to access the Internet directly.

17.1 CELLULAR TELEPHONY

Cellular telephony is designed to provide communications between two moving units, called mobile stations (MSs), or between one mobile unit and one stationary unit, often called a land unit. A service provider must be able to locate and track a caller, assign a channel to the call, and transfer the channel from base station to base station as the caller moves out of range.

To make this tracking possible, each cellular service area is divided into small regions called cells. Each cell contains an antenna and is controlled by a small office, called the base station (BS). Each base station, in turn, is controlled by a switching office, called a **mobile switching center (MSC)**. The MSC coordinates communication between all the base stations and the telephone central office. It is a computerized center that is responsible for connecting calls, recording call information, and billing (see Fig. 17.1).

Cell size is not fixed and can be increased or decreased depending on the population of the area. The typical radius of a cell is 1 to 12 miles. High-density areas require more geographically smaller cells to meet traffic demands than do lower-density areas. Once determined, cell size is optimized to prevent the interference of adjacent cell signals. The transmission power of each cell is kept low to prevent its signal from interfering with those of other cells.

Frequency-Reuse Principle

In general, neighboring cells cannot use the same set of frequencies for communication because it may create interference for the users located near the cell boundaries. However,

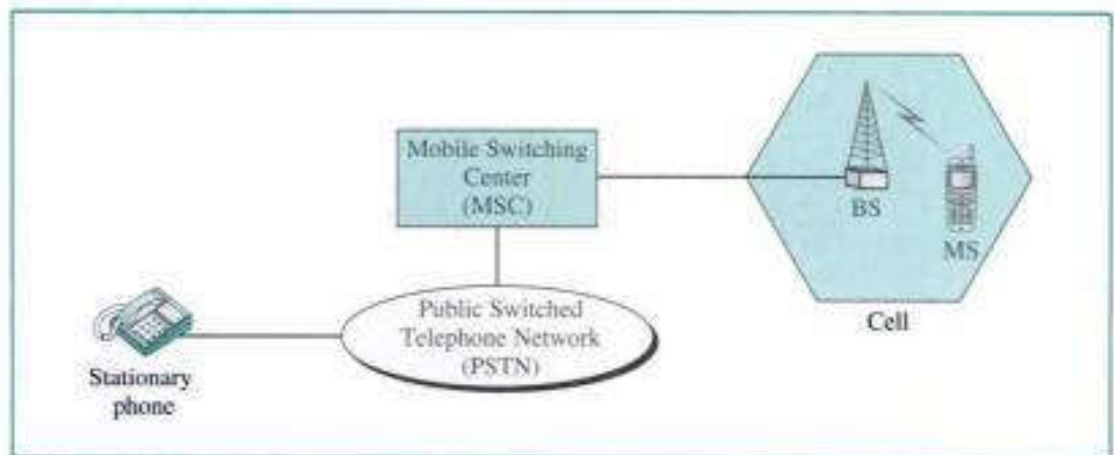
Figure 17.1 Cellular system

the set of frequencies available is limited, and frequencies need to be reused. A frequency reuse pattern is a configuration of N cells, N being the **reuse factor**, in which each cell uses a unique set of frequencies. When the pattern is repeated, the frequencies can be reused. There are several different patterns. Figure 17.2 shows two of them.

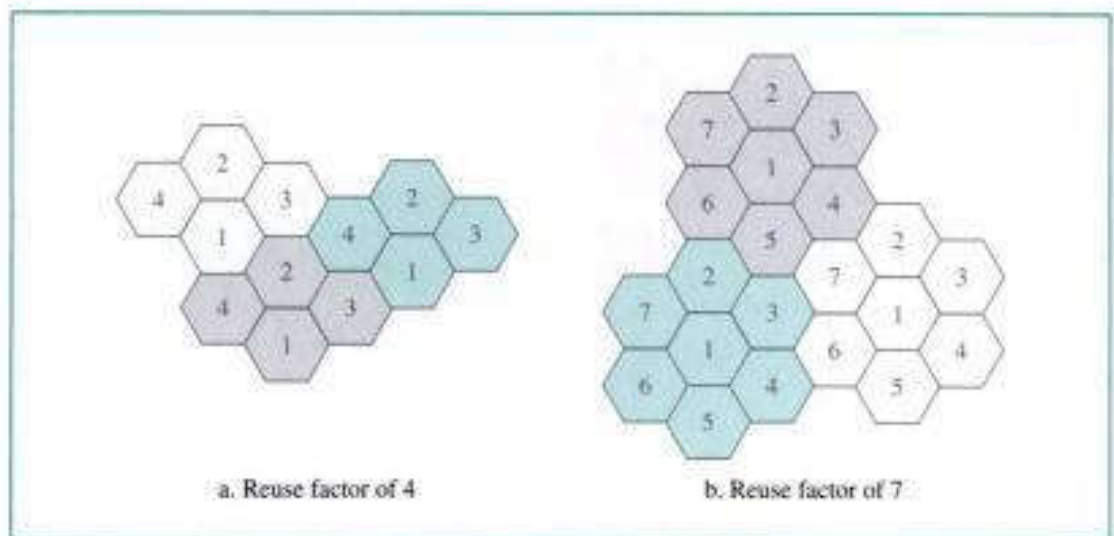
Figure 17.2 Frequency reuse patterns

The cells with the same number in a pattern can use the same set of frequencies. We call these cells the *reusing cells*. As the figure shows, in a pattern with reuse factor 4, only one cell separates the cells using the same set of frequencies. In the pattern with reuse factor 7, two cells separate the reusing cells.

Transmitting

To place a call from a mobile station, the caller enters a code of 7 or 10 digits (a phone number) and presses the send button. The mobile station then scans the band, seeking a

setup channel with a strong signal, and sends the data (phone number) to the closest base station using that channel. The base station relays the data to the MSC. The MSC sends the data on to the telephone central office. If the called party is available, a connection is made and the result is relayed back to the MSC. At this point, the MSC assigns an unused voice channel to the call, and a connection is established. The mobile station automatically adjusts its tuning to the new channel, and communication can begin.

Receiving

When a mobile phone is called, the telephone central office sends the number to the MSC. The MSC searches for the location of the mobile station by sending query signals to each cell in a process called *paging*. Once the mobile station is found, the MSC transmits a ringing signal and, when the mobile station answers, assigns a voice channel to the call, allowing voice communication to begin.

Handoff

It may happen that, during a conversation, the mobile station moves from one cell to another. When it does, the signal may become weak. To solve this problem, the MSC monitors the level of the signal every few seconds. If the strength of the signal diminishes, the MSC seeks a new cell that can better accommodate the communication. The MSC then changes the channel carrying the call (hands the signal off from the old channel to a new one).

Hard Handoff Early systems used a hard **handoff**. In a hard handoff, a mobile station only communicates with one base station. When the MS moves from one cell to another, communication must first be broken with the previous base station before communication can be established with the new one. This may create a rough transition.

Soft Handoff New systems use a soft handoff. In this case, a mobile station can communicate with two base stations at the same time. This means that, during handoff, a station may continue with the new base station before breaking from the old one.

Roaming

One feature of cellular telephony is called **roaming**. Roaming means, in principle, that a user can have access to communication or can be reached where there is coverage. A service provider usually has limited coverage. Neighboring service providers can provide extended coverage through a roaming contract. The situation is similar to snail mail between countries. The charge for delivery of a letter between two countries can be divided upon agreement by the two countries.

First Generation

Cellular telephony is now in its second generation with the third on the horizon. The first generation was designed for voice communication using analog signals. We discuss one first-generation mobile system used in North America, AMPS.

AMPS

Advanced Mobile Phone System (AMPS) is one of the leading analog cellular systems in North America. It uses FDMA to separate channels in a link.

AMPS is an analog cellular phone system using FDMA.

Bands AMPS operates in the ISM 800-MHz band. The system uses two separate analog channels for forward (base station to mobile station) and reverse (mobile station to base station) communication. The band between 824 and 849 MHz carries reverse communication; the band between 869 and 894 MHz carries forward communication. See Figure 17.3.

Figure 17.3 Cellular bands for AMPS

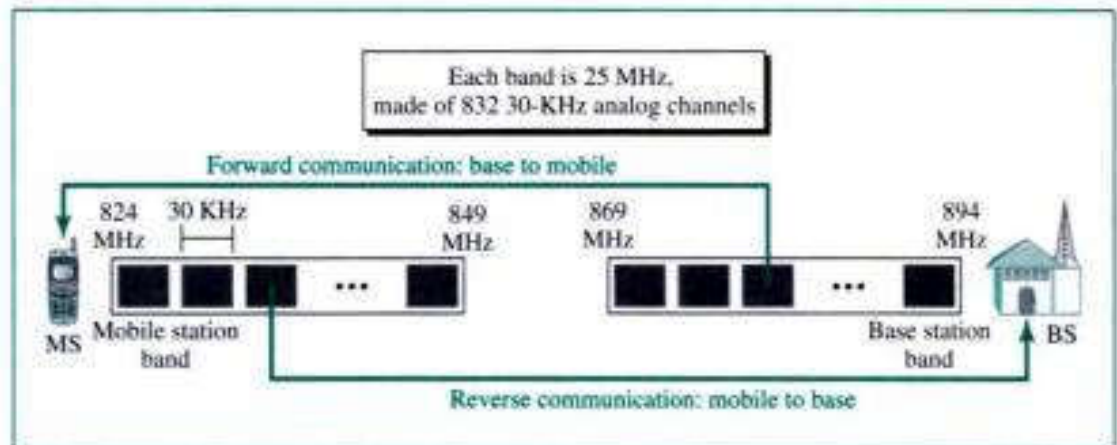

Each band is divided into 832 channels. However, two providers can share an area, which means 416 channels in each cell for each provider. Out of these 416, 21 channels are used for control, which leaves 395 channels. AMPS has a frequency reuse factor of 7; this means only one-seventh of these 395 traffic channels are actually available in a cell.

Transmission AMPS uses FM and FSK for modulation. Figure 17.4 shows the transmission in the reverse direction. Voice channels are modulated using FM, and control channels use FSK to create 30-KHz analog signals. AMPS uses FDMA to divide each 25-MHz band into 30-KHz channels.

Second Generation

To provide higher-quality (less noise-prone) mobile voice communications, the second generation of the cellular phone network was developed. While the first generation was designed for analog voice communication, the second generation was mainly designed for digitized voice. Three major systems evolved in the second generation, as shown in Figure 17.5. We will discuss each system separately.

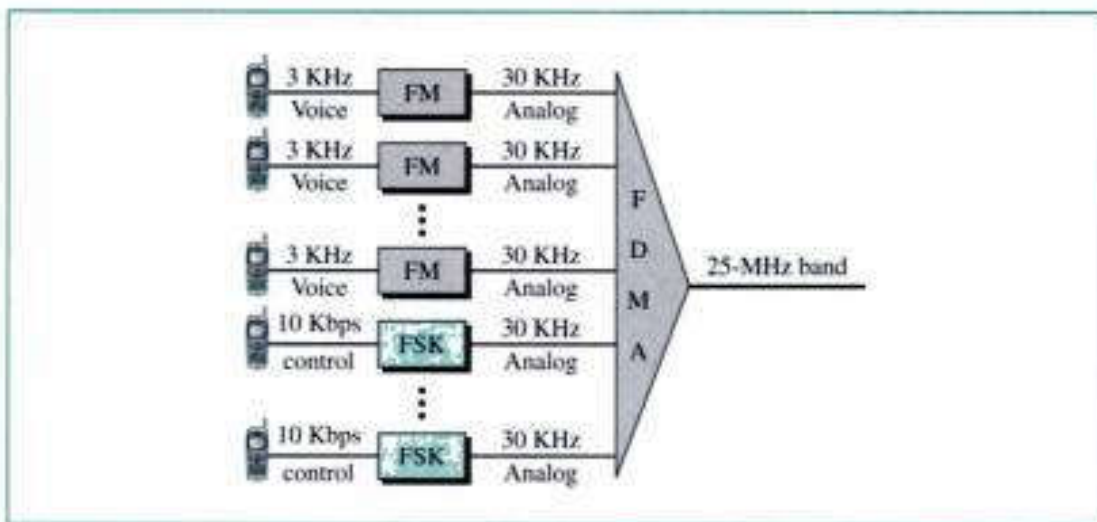
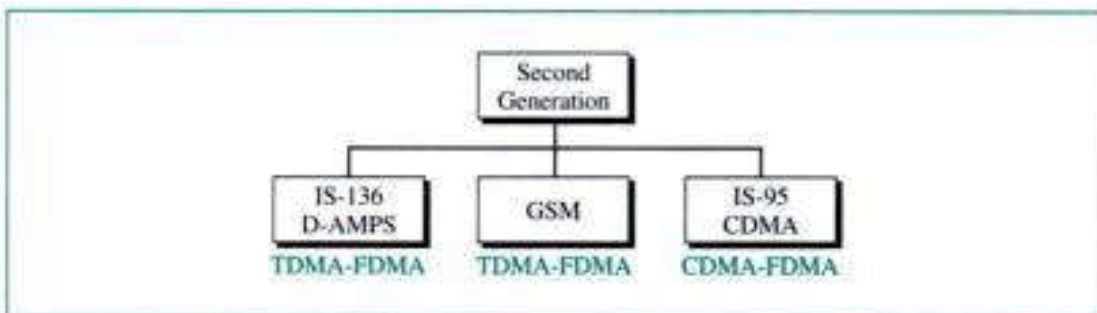
Figure 17.4 AMPS reverse communication band**Figure 17.5** Second-generation cellular phone systems

D-AMPS

The product of the evolution of the analog AMPS into a digital system is **digital AMPS (D-AMPS)**. D-AMPS was designed to be backward-compatible with AMPS. This means that in a cell, one telephone can use AMPS and another D-AMPS. D-AMPS was first defined by IS-54 (Interim Standard 54) and later revised by IS-136.

Band D-AMPS uses the same bands and channels as AMPS.

Transmission Each voice channel is digitized using a very complex PCM and compression technique. A voice channel is digitized to 7.95 Kbps. Three 7.95-Kbps digital voice channels are combined using TDMA. The result is 48.6 Kbps of digital data; much of this is overhead.

As Figure 17.6 shows, the system sends 25 frames per second, with 1944 bits per frame. Each frame lasts 40 ms ($1/25$) and is divided into six slots shared by three digital channels; each channel is allotted two slots.

Each slot holds 324 bits. However, only 159 bits comes from the digitized voice; 64 bits for control, and 101 bits for error correction. In other words, each channel drops 159 bits of data in each of the two channels assigned to it. The system adds 64 control bits and 101 error-correcting bits.

Figure 17.6 D-AMPS

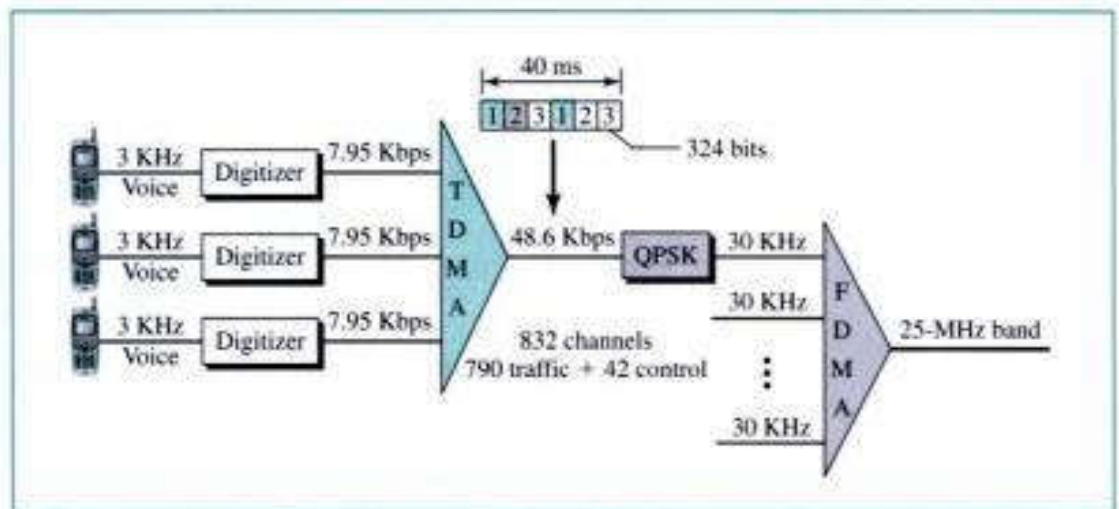

The resulting 48.6 Kbps of digital data modulates a carrier using QPSK; the result is a 30-KHz analog signal. Finally, the 30-KHz analog signals are frequency-multiplexed in the 25-MHz band. D-AMPS has a frequency reuse factor of 7.

D-AMPS, or IS-136, is a digital cellular phone system using TDMA and FDMA.

GSM

The **Global System for Mobile Communication (GSM)** is a European standard that was developed to provide a common second-generation technology for all of Europe. The aim was to replace a number of incompatible first-generation technologies.

Bands GSM uses two bands for duplex communication. Each band is 25 MHz in width, shifted toward 900 MHz, as shown in Figure 17.7. Each band is divided into 124 channels of 200 KHz separated by guard bands.

Transmission Figure 17.8 shows a GSM system. Each voice channel is digitized and compressed to a 13-Kbps digital signal. Each slot carries 156.25 bits. Eight slots are

Figure 17.7 GSM bands

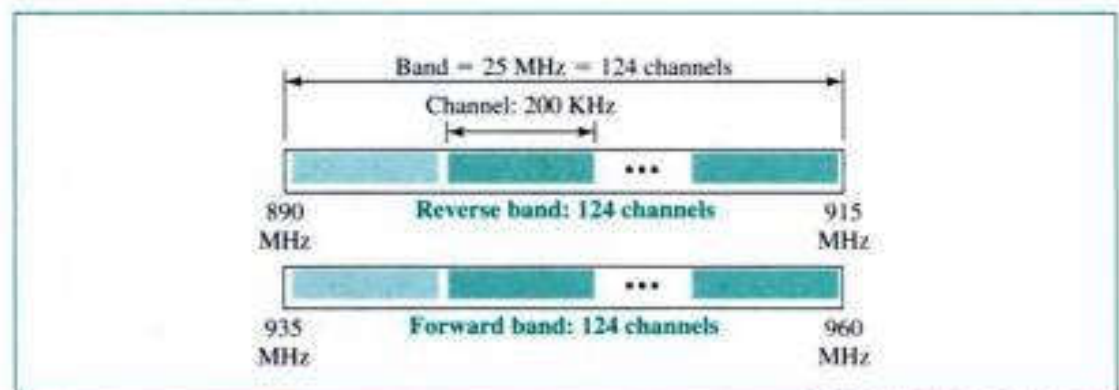
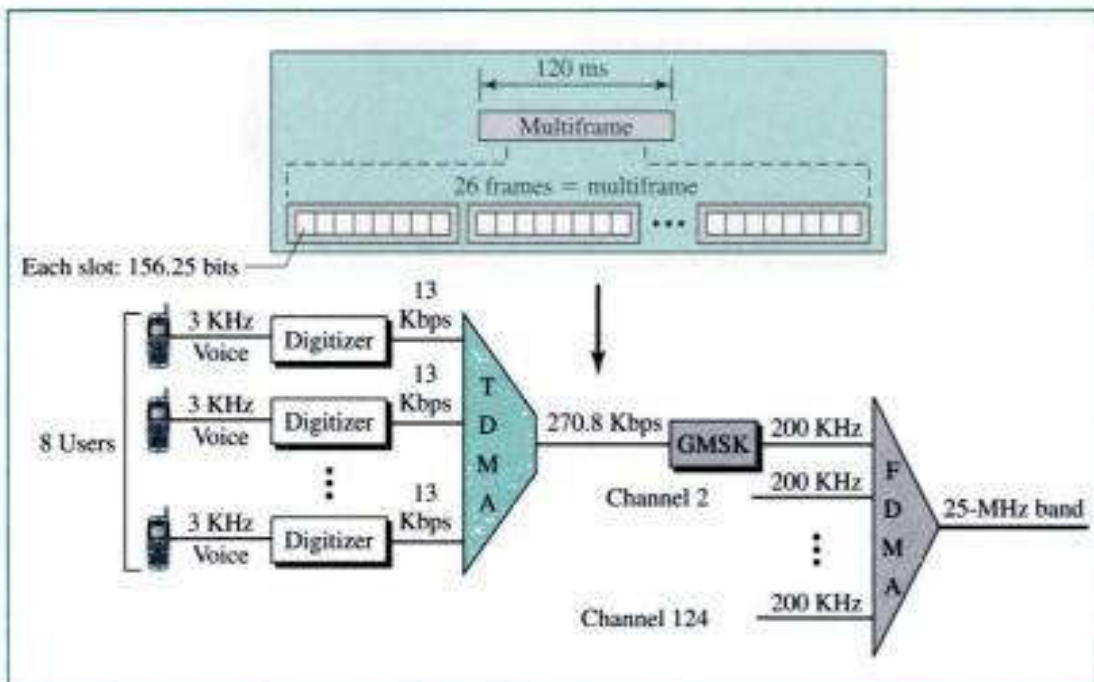

Figure 17.8 GSM



multiplexed together, creating a TDM frame. Twenty-six frames are combined to form a multiframe. We can calculate the bit rate of each channel as follows:

$$\text{Channel data rate} = (1/120 \text{ ms}) \times 26 \times 8 \times 156.25 = 270.8 \text{ Kbps}$$

Each 270.8-Kbps digital channel modulates a carrier using GMSK (a form of FSK used mainly in European systems); the result is a 200-KHz analog signal. Finally 124 analog channels of 200 KHz are multiplexed together using FDMA. The result is a 25-MHz band.

Figure 17.9 shows the user data and overhead in a multiframe.

Figure 17.9 Multiframe components

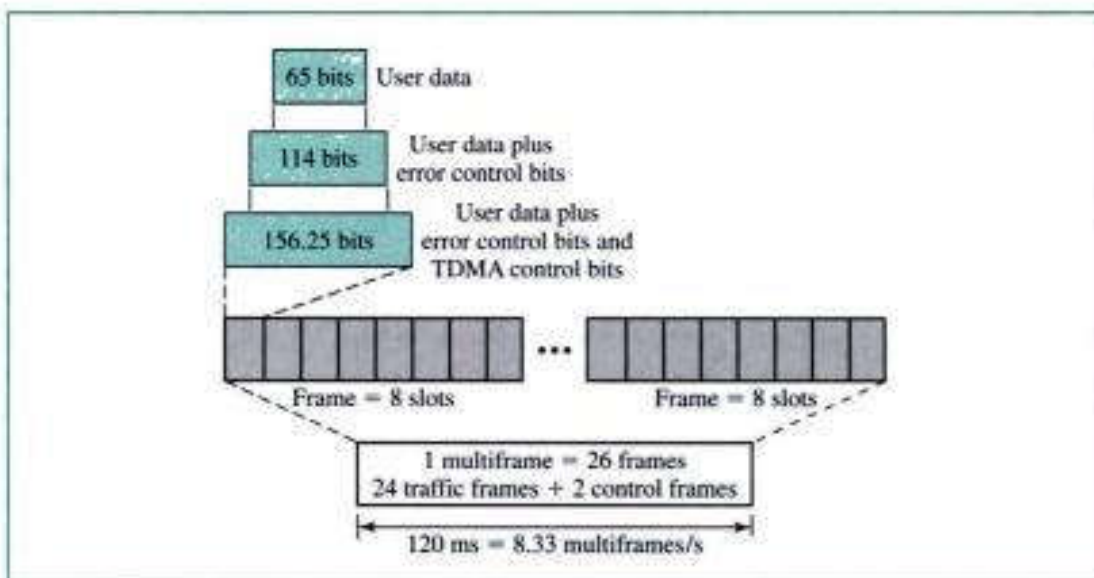

The reader may have noticed the large amount of overhead in TDMA. The user data is only 65 bits per slot. The system adds extra bits for error correction to make it 114 bits per slot. To this, control bits are added to bring it up to 156.25 bits per slot. Eight slots are encapsulated in a frame. Twenty-four traffic frames and two additional control frames make a multiframe. A multiframe has a duration of 120 ms. However, the architecture does define superframes and hyperframes that do not add any overhead; we will not discuss them here.

Reuse Factor Because of the complex error correction mechanism, GSM allows a reuse factor as low as 3.

GSM is a digital cellular phone system using TDMA and FDMA.

IS-95

One of the dominating second-generation standards in North America is **Interim Standard 95 (IS-95)**. It is based on CDMA and DSSS.

Bands and Channels IS-95 uses two bands for duplex communication. The bands can be the traditional ISM 800-MHz band or the ISM 1900-MHz band. Each band is divided into 20 channels of 1.228 MHz separated by guard bands. Each service provider is allotted 10 channels. IS-95 can be used in parallel with AMPS. Each IS-95 channel is equivalent to 41 AMPS channels ($41 \times 30 \text{ KHz} = 1.23 \text{ MHz}$).

Synchronization All base channels need to be synchronized to use CDMA. To provide synchronization, bases use the services of GPS (Global Positioning System), a satellite system that we discuss in the next section.

Forward Transmission IS-95 has two different transmission techniques: one for use in the forward (base to mobile) direction and another for use in the reverse (mobile to base) direction. In the forward direction, communications between the base and all mobiles are synchronized; the base sends synchronized data to all mobiles. Figure 17.10 shows a simplified diagram for the forward direction.

Each voice channel is digitized, producing data at a basic rate of 9.6 Kbps. After adding error-correcting and repeating bits, and interleaving, the result is a signal of 19.2 ksps (kilosignals per seconds). This output is now scrambled using a 19.2-ksps signal. The scrambling signal is produced from a long code generator that uses the electronic serial number (ESN) of the mobile station and generates 2^{42} pseudorandom chips, each chip having 42 bits. Note that the chips are generated pseudorandomly, not randomly, because the pattern repeats itself. The output of the long code generator is fed to a decimator, which chooses 1 bit out of 64 bits. The output of the decimator is used for scrambling. The scrambling is used to create privacy; the ESN is unique for each station.

The result of the scrambler is fed to the CDMA multiplexer. For each traffic channel, one Walsh 64×64 row chip is selected. The result is a signal of 1.288 Mcps (megachips per second).

$$19.2 \text{ Ksps} \times 64 \text{ cps} = 1.288 \text{ Mcps}$$

Figure 17.10 IS-95 forward transmission

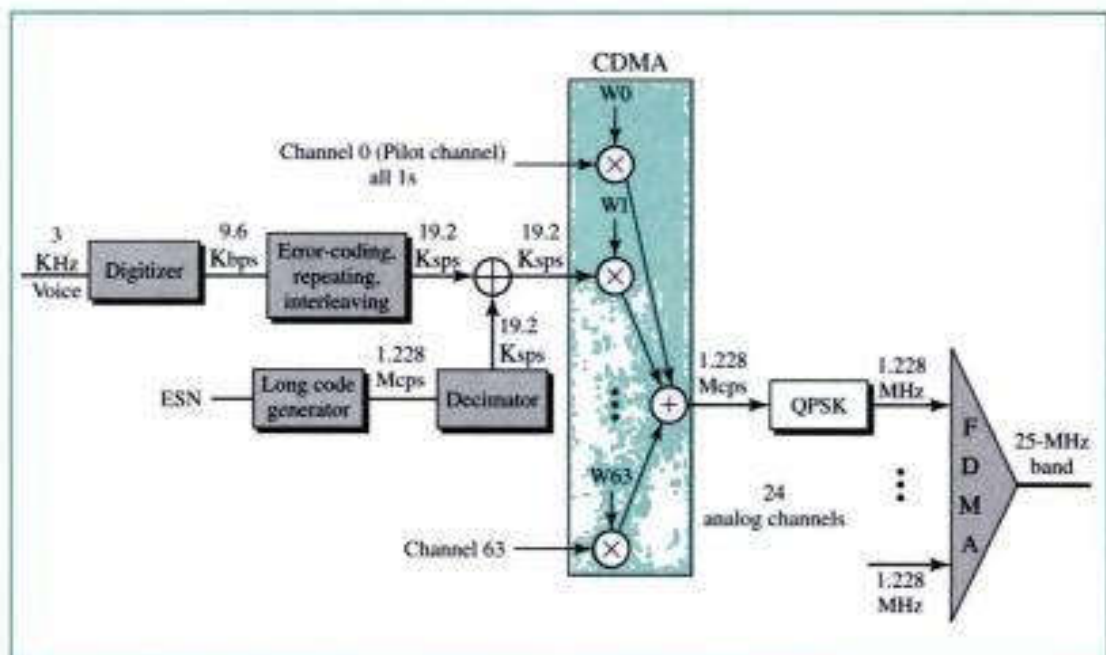

The CDMA-multiplexed signal is fed into a QPSK modulator to produce a signal of 1.288 MHz. The resulting bandwidth is shifted appropriately, using FDMA.

An analog channel creates 64 digital channels, of which 55 channels are traffic channels (carrying digitized voice). Nine channels are used for control and synchronization:

- Channel 0 is a pilot channel. This channel sends a continuous stream of 1s to mobile stations. The stream provides bit synchronization, serves as a phase reference for demodulation, and allows the mobile station to compare the signal strength of neighboring bases for handoff decisions.
- Channel 32 gives information about the system to the mobile station.
- Channels 1 to 7 are used for paging, to send messages to one or more mobile stations.
- Channels 8 to 31 and 33 to 63 are traffic channels carrying digitized voice from the base station to the corresponding mobile station.

Reverse Transmission The use of CDMA in the forward direction is possible because the pilot channel sends a continuous sequence of 1s to synchronize transmission. The synchronization is not used in the reverse direction because we need an entity to do that, which is not feasible. Instead of CDMA, the reverse channels use DSSS (direct sequence spread spectrum), which we discussed in Chapter 15. Figure 17.11 shows a simplified diagram for reverse transmission.

Each voice channel is digitized, producing data at a rate of 9.6 Kbps. However, after adding error-correcting and repeating bits, plus interleaving, the result is a signal of 28.8 Ksps. The output is now passed through a 6/64 symbol modulator. The symbols are divided into six-symbol chunks, and each chunk is interpreted as a binary number (from 0 to 63). The binary number is used as the index to a 64×64 Walsh matrix for

Figure 17.11 IS-95 reverse transmission

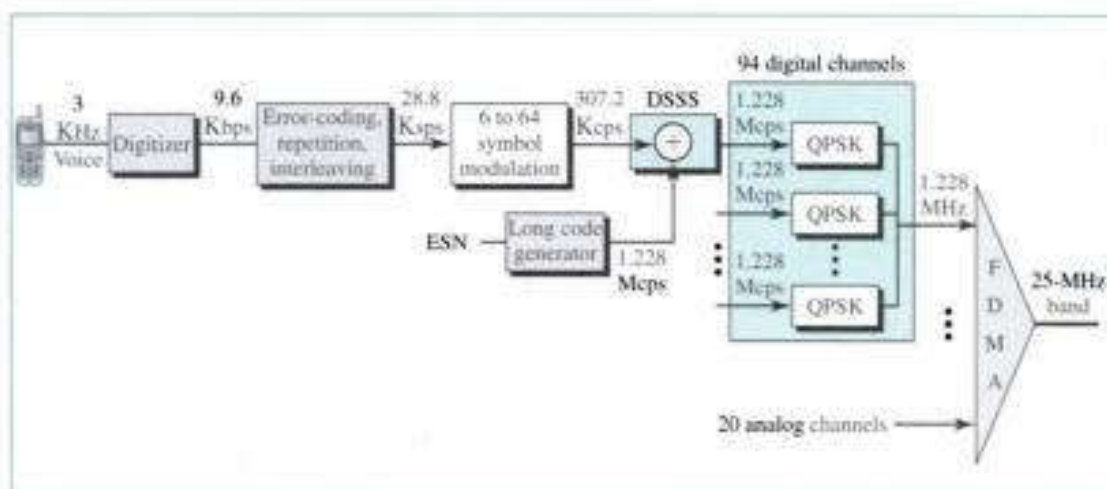

selection of a row of chips. Note that this procedure is not CDMA; each bit is not multiplied by the chips in a row. Each six-symbol chunk is replaced by a 64-chip code. This is done to provide a kind of orthogonality; it differentiates the streams of chips from the different mobile stations. The result creates a signal of 307.2 kcps or $(28.8/6) \times 64$.

Spreading is the next step; each chip is spread into 4. Again the ESN of the mobile station creates a long code of 42 bits at a rate of 1.228 Mcps, which is 4 times 307.2. After spreading, each signal is modulated using QPSK, which is slightly different from the one used in the forward direction; we do not go into details here. Note that there is no multiple-access mechanism here; all reverse channels send their analog signal into the air, but the correct chips will be received by the base station due to spreading.

Although we can create $2^{42} - 1$ digital channels in the reverse direction (because of the long code generator), normally 94 channels are used; 62 are traffic channels, and 32 are channels used to gain access to the base station.

IS-95 is a digital cellular phone system using CDMA/DSSS and FDMA.

Two Data Rate Sets IS-95 defines two data rate sets, with four different rates in each set. The first set defines 9600, 4800, 2400, and 1200 bps. If, for example, the selected rate is 1200 bps, each bit is repeated 8 times to provide a rate of 9600 bps. The second set defines 14,400, 7200, 3600, and 1800 bps. This is possible by reducing the number of bits used for error correction. The bit rates in a set are related to the activity of the channel. If the channel is silent, only 1200 bits can be transferred, which improves the spreading by repeating each bit 8 times.

Frequency Reuse Factor In an IS-95 system, the frequency reuse factor is normally 1 because the interference from neighboring cells cannot affect CDMA or DSSS transmission.

Soft Handoff Every base station continuously broadcasts signals using its pilot channel. This means a mobile station can detect the pilot signal from its cell and neighboring cells. This enables a mobile station to do a soft handoff in contrast to a hard handoff.

PCS

Before we leave the discussion on second-generation cellular telephones, let us explain a term generally heard in relation to this generation: PCS. **Personal Communications System (PCS)** does not refer to a single technology such as GSM, IS-136, or IS-95. It is a generic name for a commercial system that offers several kinds of communication services. Common features of these systems can be summarized:

1. They may use any second-generation technology (GSM, IS-136, or IS-95).
2. They use the 1900-MHz band, which means that a mobile station needs more power because higher frequencies have a shorter range than lower ones. However, since a station's power is limited by the FCC, the base station and the mobile station need to be close to each other (smaller cells).
3. They offer communication services such as short message service (SMS) and limited Internet access.

Third Generation

The third generation of cellular telephony refers to a combination of technologies that provide a variety of services. Ideally, when it matures, the third generation can provide both digital data and voice communication. Using a small portable device, a person should be able to talk to anyone else in the world with a voice quality similar to that of the existing fixed telephone network. A person can download and watch a movie, can download and listen to music, can surf the Internet or play games, can have a video conference, and can do much more. One of the interesting characteristics of a third-generation system is that the portable device is always connected; you do not need to dial a number to connect to the Internet.

The third-generation concept started in 1992, when ITU issued a blueprint called **Internet Mobile Communication for year 2000 (IMT-2000)**. The blueprint defines some criteria for 3G technology as outlined below:

- Voice quality comparable to that of the existing public telephone network.
- Data rate of 144 Kbps for access in a moving vehicle (car), 384 Kbps for access as the user walks (pedestrians), and 2 Mbps for the stationary user (office or home).
- Support for packet-switched and circuit-switched data services.
- A band of 2 GHz.
- Bandwidths of 2 MHz.
- Interface to the Internet.

The main goal of third-generation cellular telephony is to provide universal personal communication.

IMT-2000 Radio Interface

Figure 17.12 shows the radio interfaces (wireless standards) adopted by IMT-2000. All five are developed from second-generation technologies. The first two evolve from CDMA technology. The third evolves from a combination of CDMA and TDMA. The fourth evolves from TDMA, and the last evolves from both FDMA and TDMA.

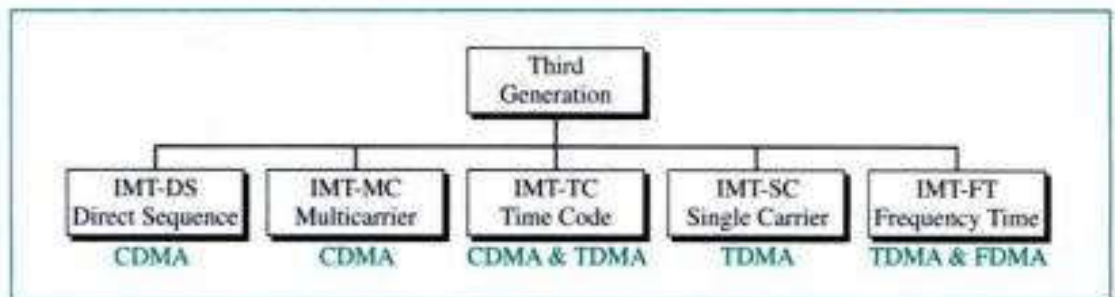
Figure 17.12 *IMT-2000 radio interfaces*

IMT-DS This approach uses a version of CDMA called wideband CDMA or W-CDMA. W-CDMA uses a 5-MHz bandwidth. It was developed in Europe, and it is compatible with the CDMA used in IS-95.

IMT-MC This approach was developed in North America and is known as CDMA 2000. It is an evolution of CDMA technology used in IS-95 channels. It combines the new wideband (15-MHz) spread spectrum with the narrowband (1.25-MHz) CDMA of IS-95. It is backward-compatible with IS-95. It allows communication on multiple 1.25-MHz channels (1, 3, 6, 9, 12 times), up to 15 MHz. The use of the wider channels allows it to reach the 2-Mbps data rate defined for the third generation.

IMT-TC This standard uses a combination of W-CDMA and TDMA. The standard tries to reach the IMT-2000 goals by adding TDMA multiplexing to W-CDMA.

IMT-SC This standard only uses TDMA.

IMT-FT This standard uses a combination of FDMA and TDMA.

17.2 SATELLITE NETWORKS

A **satellite network** is a combination of nodes that provides communication from one point on the earth to another. A node in the network can be a satellite, an earth station, or an end-user terminal or telephone. Although a real satellite, such as the moon, can be used as a relaying node in the network, the use of artificial satellites is preferred because we can install electronic equipment on the satellite to regenerate the signal that has lost its energy during travel. Another restriction on using natural satellites is their distances from the earth, which create a long delay in communication.

Satellite networks are like cellular networks in that they divide the planet into large cells. Satellites can provide transmission capability to and from any location on earth, no matter how remote. This advantage makes high-quality communication available to undeveloped parts of the world without requiring a huge investment in ground-based infrastructure.

Orbits

An artificial satellite needs to have an **orbit**, the path in which it travels around the earth. The orbit can be equatorial, inclined, or polar, as shown in Figure 17.13.

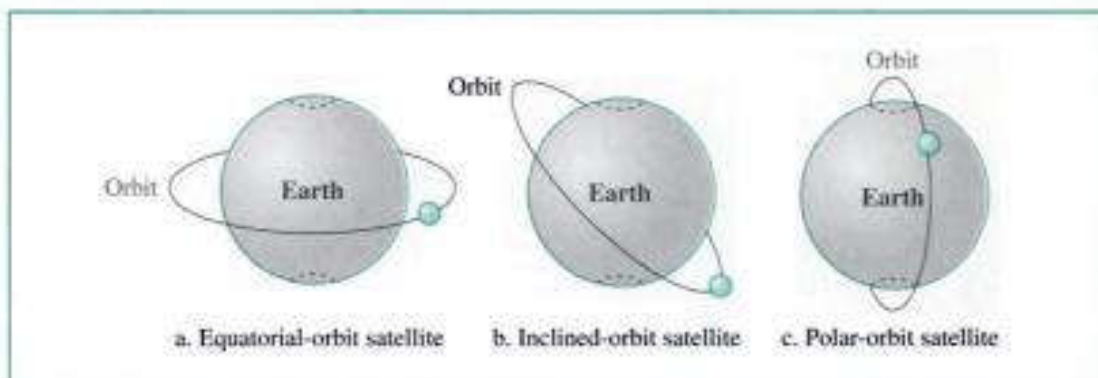
Figure 17.13 Satellite orbits

The period of a satellite, the time required for a satellite to make a complete trip around the earth, is determined by Kepler's law, which defines the period as a function of the distance of the satellite from the center of the earth.

$$\text{Period} = C \times \text{distance}^{1.5}$$

Here C is a constant approximately equal to $1/100$. The period is in seconds and the distance in kilometers.

Example 1

What is the period of the moon according to Kepler's law?

Solution

The moon is located approximately 384,000 km above the earth. The radius of the earth is 6378 km. Applying the formula, we get

$$\text{Period} = (1/100) (384,000 + 6378)^{1.5} \longrightarrow 2,439,090 \text{ s} \longrightarrow 1 \text{ month}$$

Example 2

According to Kepler's law, what is the period of a satellite that is located at an orbit approximately 35,786 km above the earth?

Solution

Applying the formula, we get

$$\text{Period} = (1/100) (35,786 + 6378)^{1.5} \longrightarrow 86,579 \text{ s} \longrightarrow 24 \text{ h}$$

This means that a satellite located at 35,786 km has a period of 24 h, which is the same as the rotation period of the earth. A satellite like this is said to be *stationary* to the earth. The orbit, as we will see, is called a geosynchronous orbit.

Footprint

Satellites process microwaves with bidirectional antennas (line-of-sight). Therefore, the signal from a satellite is normally aimed at a specific area called the **footprint**. The

signal power at the center of the footprint is maximum. The power decreases as we move from the footprint center. The boundary of the footprint is the location where the power reaches a predefined threshold.

Three Categories of Satellites

Based on the location of the orbit, satellites can be divided into three categories: GEO, LEO, and MEO. Figure 17.14 shows the taxonomy.

Figure 17.14 *Satellite categories*

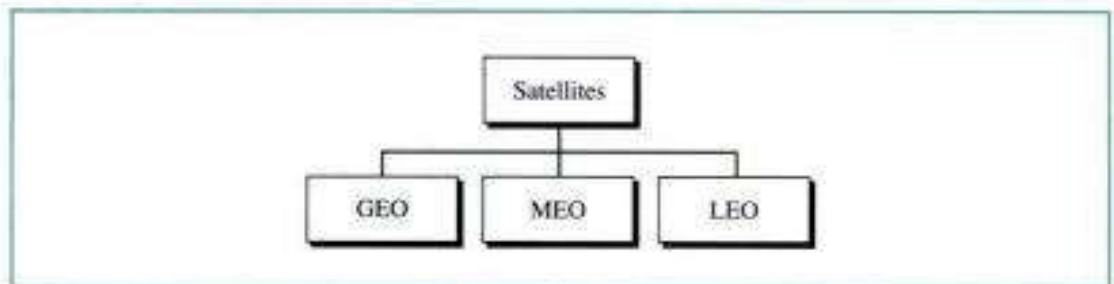
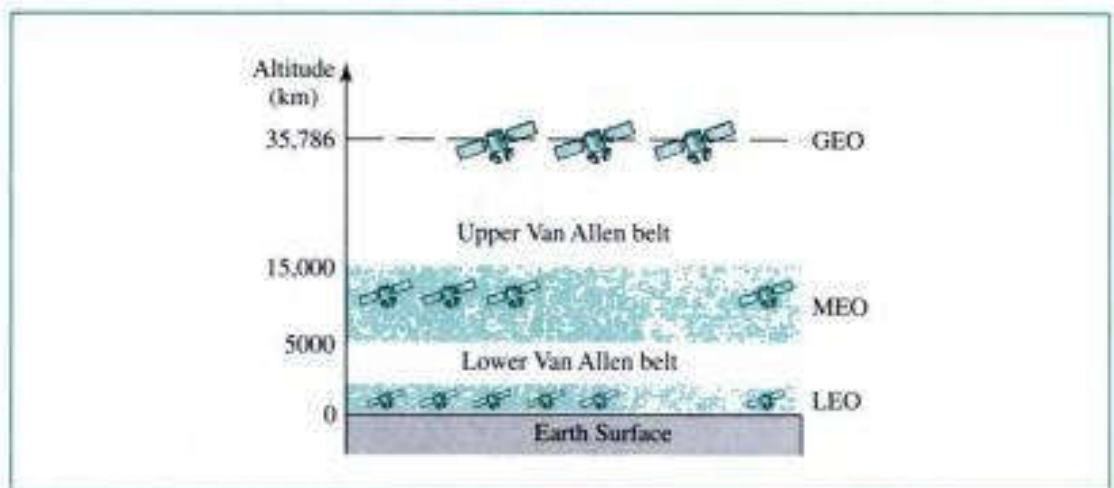

Figure 17.15 shows the satellite altitudes with respect to the surface of the earth. There is only one orbit, at an altitude of 35,786 km for the GEO satellite. MEO satellites are located at altitudes between 5000 and 15,000 km. LEO satellites are normally below an altitude of 2000 km.

Figure 17.15 *Satellite orbit altitudes*



One reason for having different orbits is due to the existence of two Van Allen belts. A Van Allen belt is a layer that contains charged particles. A satellite orbiting in one of these two belts would be totally destroyed by the energetic charged particles. The MEO orbits are located between these two belts.

Frequency Bands for Satellite Communication

The frequencies reserved for satellite microwave communication are in the gigahertz (GHz) range. Each satellite sends and receives over two different bands. Transmission from the earth to the satellite is called **uplink**. Transmission from the satellite to the earth is called **downlink**. Table 17.1 gives the band names and frequencies for each range.

Table 17.1 Satellite frequency bands

Band	Downlink, GHz	Uplink, GHz	Bandwidth, MHz
L	1.5	1.6	15
S	1.9	2.2	70
C	4	6	500
Ku	11	14	500
Ka	20	30	3500

GEO Satellites

Line-of-sight propagation requires that the sending and receiving antennas be locked onto each other's location at all times (one antenna must have the other in sight). For this reason, a satellite that moves faster or slower than the earth's rotation is useful only for short periods of time. To ensure constant communication, the satellite must move at the same speed as the earth so that it seems to remain fixed above a certain spot. Such satellites are called *geosynchronous*.

Because orbital speed is based on distance from the planet, only one orbit can be geosynchronous. This orbit occurs at the equatorial plane and is approximately 22,000 miles from the surface of the earth.

But one geosynchronous satellite cannot cover the whole earth. One satellite in orbit has line-of-sight contact with a vast number of stations, but the curvature of the earth still keeps much of the planet out of sight. It takes a minimum of three satellites equidistant from each other in **geosynchronous Earth orbit (GEO)** to provide full global transmission. Figure 17.16 shows three satellites, each 120° from another in geosynchronous orbit around the equator. The view is from the North Pole.

Figure 17.16 Satellites in geosynchronous orbit

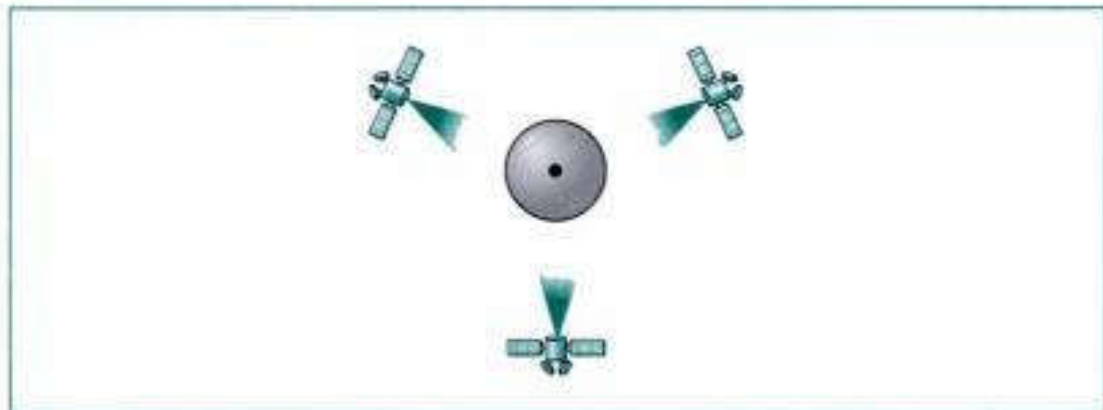

MEO Satellites

Medium-Earth orbit (MEO) satellites are positioned between the two Van Allen belts. A satellite at this orbit takes approximately 6 hours to circle the earth.

GPS

One example of a MEO satellite system is the **Global Positioning System (GPS)** orbiting at an altitude about 18,000 km (11,000 miles) above the Earth. Although GPS was put in place by the Department of Defense, it is now a public system. The system consists of 24 satellites and is used for land and sea navigation to provide time and locations for vehicles and ships. The GPS is not used for communications.

GPS is based on a principle called **triangulation**. On a plane, if we know our distance from three points, we know exactly where we are. Let us say that we are 10 miles away from point A, 12 miles away from point B, and 15 miles away from point C. If we draw three circles with the centers at A, B, and C, we must be somewhere on circle A, somewhere on circle B, and somewhere on circle C. These three circles meet at one single point (if our distances are correct), our position. Figure 17.17 shows the concept. In space, however, the situation is different. Three spheres meet in two points; we need four spheres. If we know our distance from four points, we can find out where we are.

Figure 17.17 *Triangulation*

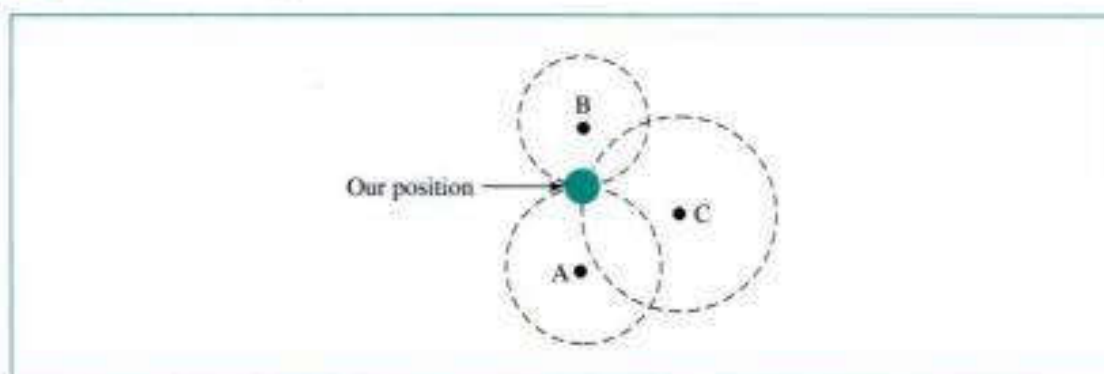

GPS uses 24 satellites in six orbits, as shown in Figure 17.18. The orbits and the locations of the satellites in each orbit are designed in such a way that, at any time, four satellites are visible from any point on Earth. A GPS receiver has an almanac that tells the current position of a satellite. It then sends a signal to four satellites and measures how long it takes for the signal to return. It calculates your position on the Earth. A GPS receiver can also show you where you are on a map.

GPS is used by military forces. For example, thousands of portable GPS receivers were used during the Persian Gulf war by foot soldiers, vehicles, and helicopters. Another use of GPS is in navigation. The driver of a car can find the location of the car. The driver can then consult a database in the memory of the automobile to be directed to the destination. In other words, GPS gives the location of the car, and the database uses this information to find a path to the destination. As we mentioned previously, the IS-95 cellular telephone system uses GPS to create synchronization between the base stations.

Figure 17.18 GPS

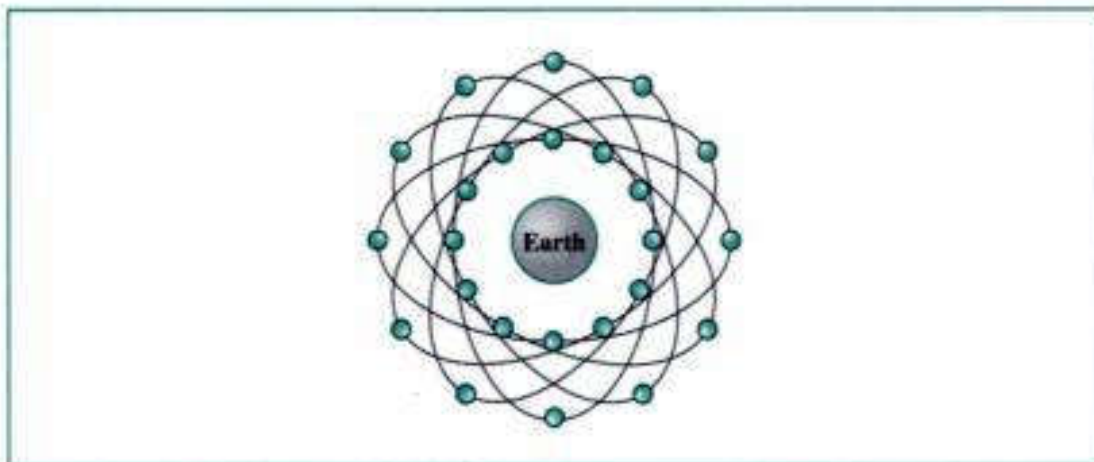

LEO Satellites

Low-Earth orbit (LEO) satellites have polar orbits. The altitude is between 500 to 2000 km, with a rotation period of 90 to 120 min. The satellite has a speed of 20,000 to 25,000 km/h. An LEO system usually has a cellular type of access, similar to the cellular telephone system. The footprint normally has a diameter of 8000 km. Because LEO satellites are close to the Earth, the round-trip time propagation delay is normally less than 20 ms, which is acceptable for audio communication.

A LEO system is made of a constellation of satellites that work together as a network; each satellite acts as a switch. Satellites that are close to each other are connected through intersatellite links (ISLs). A mobile system communicates with the satellite through a user mobile link (UML). A satellite can also communicate with an earth station (gateway) through a gateway link (GWL). Figure 17.19 shows a typical LEO satellite network.

LEO satellites can be divided into three categories: little LEOs, big LEOs, and broadband LEOs. The little LEOs operate under 1 GHz. They are mostly used for low-data-rate messaging. The big LEOs operate between 1 and 3 GHz. Globalstar and Iridium systems are examples of big LEOs. The broadband LEOs provide communication similar to fiber-optic networks. The first broadband LEO system was Teledesic.

Figure 17.19 LEO satellite system

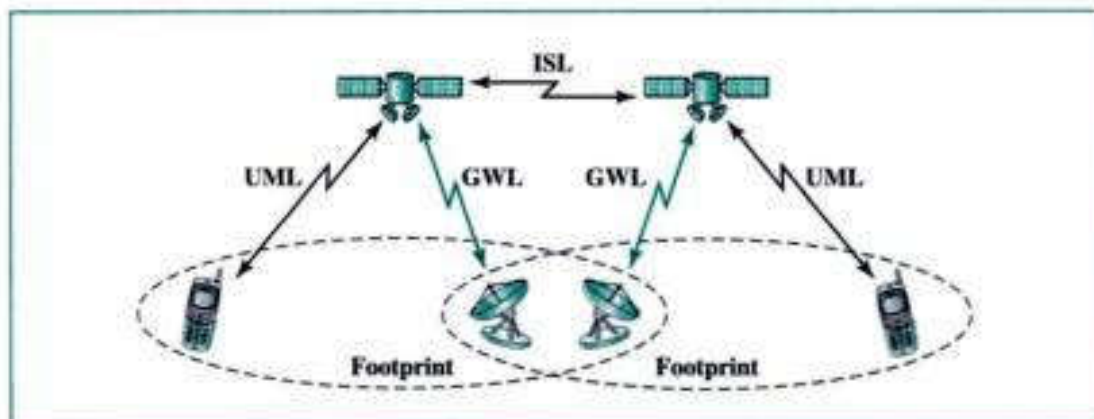

Iridium System

The concept of the **Iridium** system, a 77-satellite network, was started by Motorola in 1990. The project took 8 years to materialize. During this period, the number of satellites was reduced. Finally, in 1998, the service started with 66 satellites. The original name, Iridium, came from the name of the 77th chemical element; a more appropriate name is Dysprosium (the name of element 66).

Iridium has gone through rough times. The system was halted in 1999 due to financial problems; it was sold and restarted in 2001 under new ownership.

The system has 66 satellites divided into six orbits, with 11 satellites in each orbit. The orbits are at an altitude of 750 km. The satellites in each orbit are separated from one another by approximately 32° of latitude. Figure 17.20 shows a schematic diagram of the constellation.

Figure 17.20 *Iridium constellation*

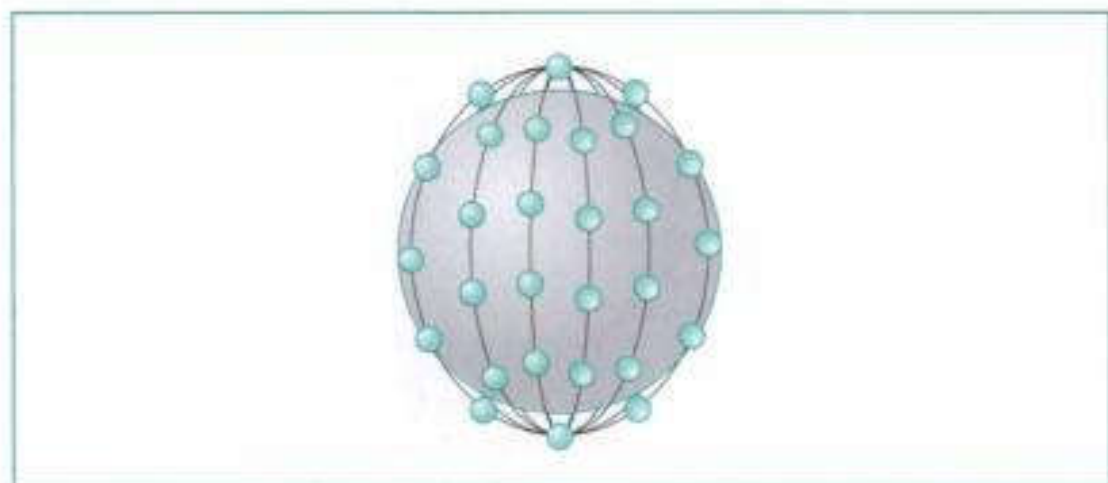

The Iridium system has 66 satellites in six LEO orbits, each at an altitude of 750 km.

Since each satellite has 48 spot beams, the system can have up to 3168 beams. However, some of the beams are turned off as the satellite approaches the pole. The number of active spot beams at any moment is approximately 2000. Each spot beam covers a cell on the earth, which means that the earth is divided into approximately 2000 (overlapping) cells.

In the Iridium system, communication between two users takes place through satellites. When a user calls another user, the call can go through several satellites before reaching the destination. This means that relaying is done in space and each satellite needs to be sophisticated enough to do relaying. This strategy eliminates the need for many terrestrial stations.

The whole purpose of Iridium is to provide direct worldwide communication using handheld terminals (same concept as cellular telephony). The system can be used for voice, data, paging, fax, and even navigation. The system can provide connectivity between users at locations where other types of communication are not possible. The system provides 2.4- to 4.8-Kbps voice and data transmission between portable telephones.

Transmission occurs in the 1.616- to 1.6126-GHz frequency band. Intersatellite communication occurs in the 23.18- to 23.38-GHz frequency band.

Iridium is designed to provide direct worldwide voice and data communication using handheld terminals, a service similar to cellular telephony but on a global scale.

Globalstar

Globalstar is another LEO satellite system. The system uses 48 satellites in six polar orbits with each orbit hosting eight satellites. The orbits are located at an altitude of almost 1400 km.

The Globalstar system is similar to the Iridium system; the main difference is the relaying mechanism. Communication between two distant users in the Iridium system requires relaying between several satellites; Globalstar communication requires both satellites and earth stations, which means that ground stations can create more powerful signals.

Teledesic

Teledesic is a system of satellites that provides fiber-optic-like (broadband channels, low error rate, and low delay) communication. Its main purpose is to provide broadband Internet access for users all over the world. It is sometimes called "Internet in the sky."

The project was started in 1990 by Craig McCaw and Bill Gates; later, other investors joined the consortium. The project is scheduled to be fully functional in 2005.

Constellation Teledesic provides 288 satellites in 12 polar orbits with each orbit hosting 24 satellites. The orbits are at an altitude of 1350 km, as shown in Figure 17.21.

Figure 17.21 *Teledesic*

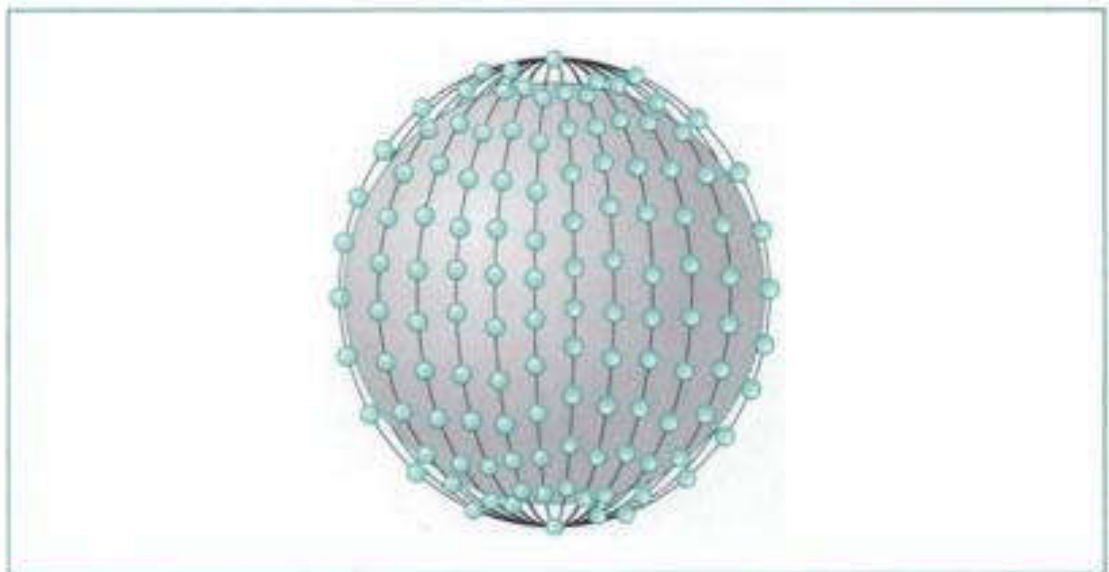

Teledesic has 288 satellites in 12 LEO orbits, each at an altitude of 1350 km.

Communication The system provides three types of communication. Intersatellite communication allows eight neighboring satellites to communicate with one another. Communication is also possible between a satellite and an earth gateway station. Users can communicate directly with the network using terminals. The earth is divided into tens of thousands of cells. Each cell is assigned a time slot, and the satellite focuses its beam to the cell at the corresponding time slot. The terminal can send data during its time slot. A terminal receives all packets intended for the cell, but selects only those intended for its address.

Bands Transmission occurs in the Ka bands.

Data Rate The data rate is up to 155 Mbps for the uplink and up to 1.2 Gbps for the downlink.

17.3 KEY TERMS

Advanced Mobile Phone System (AMPS)	Iridium
cellular telephony	low-Earth orbit (LEO)
digital AMPS (D-AMPS)	medium-Earth orbit (MEO)
downlink	mobile switching center (MSC)
footprint	orbit
geosynchronous Earth orbit (GEO)	personal communications system (PCS)
Global Positioning System (GPS)	reuse factor
Global System for Mobile Communication (GSM)	roaming
Globalstar	satellite network
handoff	Teledesic
Interim Standard 95 (IS-95)	triangulation
Internet Mobile Communication for year 2000 (IMT-2000)	uplink

17.4 SUMMARY

- Cellular telephony provides communication between two devices. One or both may be mobile.
- A cellular service area is divided into cells.
- Advanced Mobile Phone System (AMPS) is a first-generation cellular phone system.
- Digital AMPS (D-AMPS) is a second-generation cellular phone system that is a digital version of AMPS.
- Global System for Mobile Communication (GSM) is a second-generation cellular phone system used in Europe.
- Interim Standard 95 (IS-95) is a second-generation cellular phone system based on CDMA and DSSS.

- The third-generation cellular phone system will provide universal personal communication.
- A satellite network uses satellites to provide communication between any points on earth.
- A geosynchronous Earth orbit (GEO) is at the equatorial plane and revolves in phase with the earth.
- Global Positioning System (GPS) satellites are medium-Earth-orbit (MEO) satellites that provide time and location information for vehicles and ships.
- Iridium satellites are low-Earth-orbit (LEO) satellites that provide direct universal voice and data communications for handheld terminals.
- Teledesic satellites are low-Earth-orbit satellites that will provide universal broadband Internet access.

17.5 PRACTICE SET

Review Questions

1. What is the relationship between a base station and a mobile switching center?
2. What are the functions of a mobile switching center?
3. Which is better, a low reuse factor or a high reuse factor? Explain your answer.
4. What is the difference between a hard handoff and a soft handoff?
5. What is AMPS?
6. What is the relationship between D-AMPS and AMPS?
7. What is GSM?
8. What is the function of the CDMA multiplexer in IS-95?
9. What are the three types of orbits?
10. Which type of orbit does a GEO satellite have? Explain your answer.
11. What is a footprint?
12. What is the relationship between the Van Allen belts and satellites?
13. Compare an uplink with a downlink.
14. What is the purpose of GPS?
15. What is the main difference between Iridium and Globalstar?

Multiple-Choice Questions

16. A _____ is a computerized center that is responsible for connecting calls, recording call information, and billing.
 - a. Base station
 - b. Mobile switching center
 - c. Cell
 - d. Mobile station